

**OPERATION AND MAINTENANCE MANUAL  
FOR  
RIKEN SMART IR GAS DETECTOR/TRANSMITTER  
MODEL SD-805RI**

**FOR USERS**

**Safety precautions**

1. Read and understand the instructions in this manual before operating this instrument.
2. Keep manual accessible at all times.
3. This detector cannot be used for any other purpose than what is specified in this manual.
4. Follow all the instructions in this manual, any deviation will compromise the safety, quality and performance of this instrument.
5. We do not make compensation for any accident or damage caused by the use of this detector/transmitter.

Compensation is limited for the replacement of product or parts within a guaranteed clauses.



**RIKEN KEIKI CO., LTD.**

2-7-6 Azusawa Itabashi-ku Tokyo, 174-8744 Japan

Phone : 81-3-3966-1113  
Fax : 81-3-3558-9110 G111  
E-mail :  
intdept@rikenkeiki.co.jp

## Introduction

Thank you for purchasing our Smart IR Gas Detector/Transmitter SD-805RI.

This is a gas detector to detect the combustible gas leaking into the atmosphere, thereby preventing explosion of such a gas. This manual is a guidebook for use of the SD-805RI. All persons who use this detector for the first time and who has ever used this detector are requested to read through the manual to understand the content before use.

This manual contains the following headings to ensure the safe and effective operation.



Indicates an imminently hazardous situation which, if not avoided, will result in serious damage to the human life and body or product.



Indicates a potentially hazardous situation which, if not avoided, could result in serious injury or damage on the human body or object.



Indicates a potentially hazardous situation which, if not avoided, may result in minor or moderate injury or some damage on the human body or object.

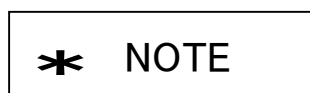

This means “ADVICE” at operation.

## Contents

1. FUNCTIONS OF THE PRODUCT .....	3
2. HANDLING	
2-1 Before initial use .....	6
2-2 Caution for installation and handling.....	6
2-3 Caution for system engineering.....	7
2-4 Maintenance space .....	9
2-5 Installation method .....	9
2-6 Wiring method .....	11
3. OPERATION	
3-1 Start up method.....	17
3-2 Gas alarm function.....	17
3-3 Trouble alarm function.....	18
3-4 Confirmation of preset alarm point .....	18
4. MAINTENANCE AND INSPECTION	
4-1 Inspection frequency and items .....	19
4-2 Replacement of parts .....	20
4-3 Maintenance mode.....	21
4-4 Gas sensitivity calibration.....	22
4-5 Adjustment of 4mA output .....	26
4-6 Change of alarm point .....	26
4-7 Alarm (Transmission)test.....	27
4-8 Setting of point skip .....	28
4-9 Storage or treatment when not in use for a long time .....	28
5. TREATMENT AT AN ABNORMAL CASE	
5-1 Trouble indication and countermeasure.....	29
5-2 Trouble shooting .....	29
6. DEFINITION OF TERMS .....	32
7. PRODUCT SPECIFICATIONS	
7-1 Standard specifications .....	33
7-2 Standard accessories.....	34
8. DETECTION PRINCIPLE .....	34
9. WARRANTY .....	35

# 1. FUNCTIONS OF THE PRODUCT

## Overall view

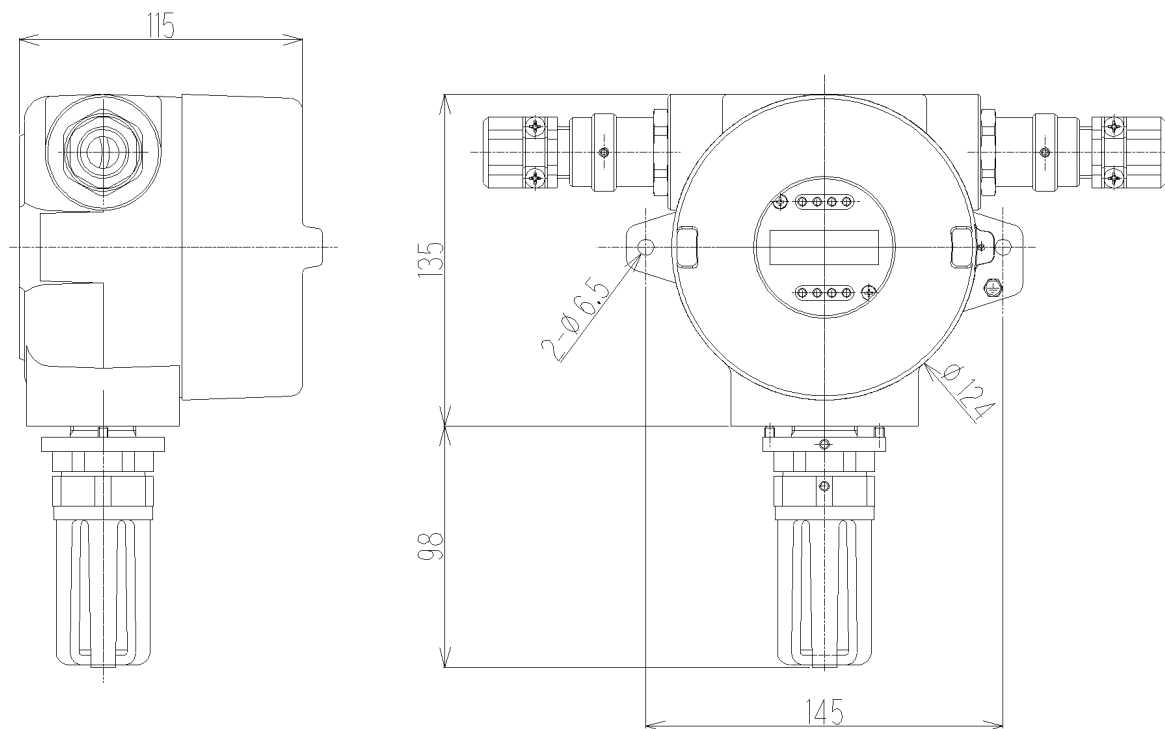

Control key



## ⚠ WARNING

The control key used for adjustment is made from a powerful magnet. If it is brought nearer to a credit card, ID card, or other magnetic products, this key may damage the store data.

## Display part

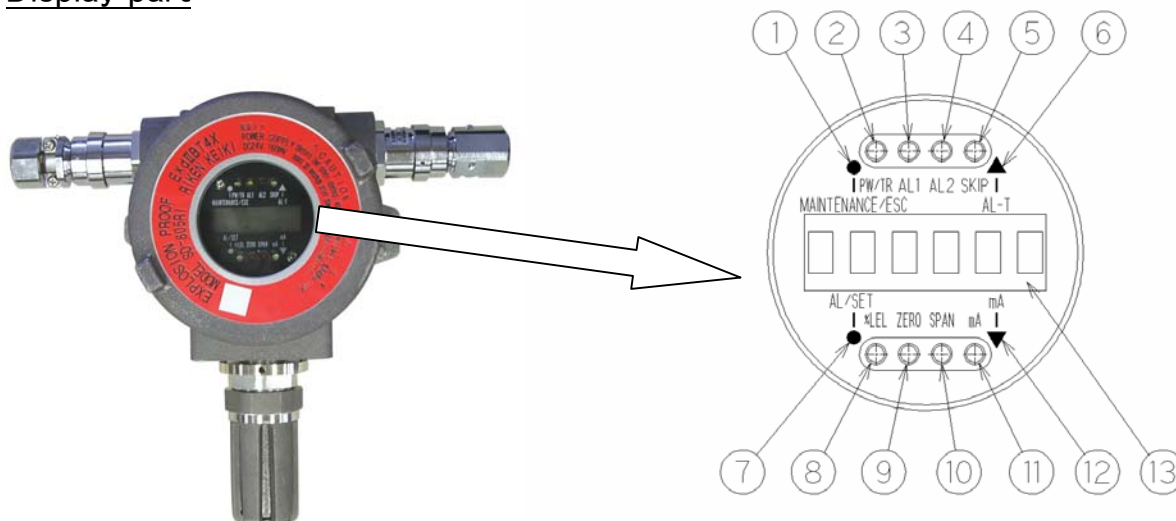

- ① Maintenance /ESC switch   ••• Used for entering into the maintenance mode with the control key. And used for cancel the maintenance mode.
- ② PW/TR light   •••• Lit on continuously while the equipment is working (power status light). And flickers in the case of abnormality in the equipment.
- ③ AL1 light   ••••• Lit on when 1<sup>st</sup> alarm is activating.
- ④ AL2 light   ••••• Lit on when 2<sup>nd</sup> alarm is activating.
- ⑤ SKIP light   ••••• Lit on when point skip is selected. And flickers in the maintenance mode.
- ⑥ AL-T(▲) switch   Used for increase in the value with the control key. (during maintenance mode.)
- ⑦ AL/SET switch   •• Used for confirmation of alarm point. And used for decision in the maintenance mode.
- ⑧ %LEL light   ••••• Lit on continuously when the gas concentration is to be indicated in “%LEL”.
- ⑨ ZERO light   ••••• Flickers in the zero adjustment mode. (Lit on continuously when the adjustment is over.)
- ⑩ SPAN light   ••••• Flickers in the span adjustment mode. (Lit on continuously when the adjustment is over.)
- ⑪ mA light   ••••• Lit on when the current output is indicated on the LCD (during maintenance).
- ⑫ mA(▼) switch   •• Used for indicating current output on the LCD. And used to decrease the indication in the maintenance mode.
- ⑬ LCD   ••••• Indicates the gas concentration and error code.

## Internal view

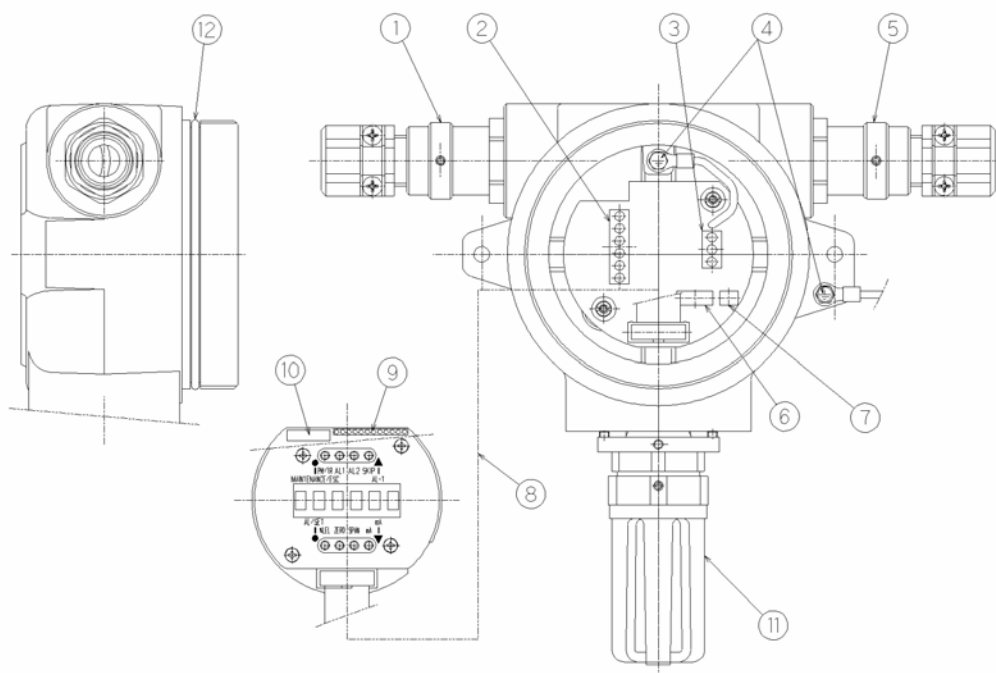

- ① Cable inlet(for relay output) ..... Used to lead the cable for alarm relay output(With pressure proof packing gland.)
- ② Relay output terminal(6P) ..... To connect the cable for alarm relay output.
- ③ Terminal for power source(3P) ... To connect the cable for power source and signal output.
- ④ Earth terminal .....For protective grounding.
- ⑤ Cable inlet(for power source) .....Used to lead the cable from the indicating/alarm unit (with the pressure proof packing gland)
- ⑥ 5P connector for sensor .....To connect the cable for sensor.
- ⑦ 2P connector for sensor.....To connect the cable for sensor(IR source) (IR source)
- ⑧ Internal connection cable ..... To connect LCD board and main board.
- ⑨ Connector for checking signals ... Used to check the circuit voltage, signals, etc.
- ⑩ Connector for program ..... Used to change the program.
- ⑪ Gas sensor ass'y ..... IR gas sensor is connected.
- ⑫ O-ring..... Used to protect equipment from water and dust.

## 2. HANDLING

### 2-1 Before initial use

On detecting any leaking combustible gas, this unit shows the gas concentration on the LCD and outputs the gas concentration value in 4-20mA to the indicator/alarm unit. When the concentration exceeds the preset level, the alarm contact activates.

This detector may also be sensitive to gases other than the objective gas. When the detector detects the gas and issues alarm, find out whether this is caused by the objective gas or other gases not covered by the detector. In view of its duty, the gas detector must always be in the normal operation with the power supply ON. Therefore, it is essential to confirm its operation daily.

For the operation confirmation, refer to [4-1, Inspection frequency and items].

### 2-2 Caution for installation and handling

Never use the detector in the following places.



- ① Place where the detector is splashed with water.

(Use an optional drip-proof cover when the detector is to be installed outdoors.)



- ② Place with vibration



- ③ Place with radio wave and noise.



- ④ Place where the detector is dropped or exposed to strong impact readily.



- ⑤ Place where the temperature is below  $-10^{\circ}\text{C}$  or  $+40^{\circ}\text{C}$  or more.

 **CAUTION**

- Be sure to use an optional drip—proof cover when the detector is to be installed outdoors.
- When open the detector lid, wait at least 30 seconds or more after power OFF.
- Do not give an impact. Gas concentration reading will increase (issuing alarm) or the detector may be damaged.

## 2—3 Caution for system engineering

Unstable power supply and noise may cause error of performance and alarm.

For the system to use this detector, it is required to make design based on these characteristics.

### (1) Stable power used

While the system gets stable at power on and power failure, the external output and alarm light may be on and the care for it must be taken. In such case, use the stand-by battery or take an appropriate action in the receiver side.

Supply the following power to this detector.

- Power voltage :  $\text{DC}24\text{V} \pm 10\%$
- Power failure tolerance time : Approx. 10msec or less  
(For power failure of above 10msec, it re-starts)

To warrant the continuous operation, install the stand-by battery outside.

### (2) Noise measures according to installation circumstances.

#### ① Lightning (Thunder) surge

There is the problem point “Lightning (Thunder)” when installing the detector outside of factory. If the lightning is a huge generation source, the cable is a reception antenna and there is the case that cable connecting instrument is broken. It is impossible to prevent the generation of lightning. If the cable should put in metal tube, laid in the underground, it is impossible to prevent the inductive lightning surge generating from the thunder.



## ② Lightning (Thunder) measures

There is no complete countermeasure for it but the following method can be considered.  
Make the suitable treatment accordingly.

### <Countermeasure by the lightning arrester (Cable safety retainer)>

There is the way to install the lightning arrester just before the field apparatus and the central control station. The position of the lightning arrester installation is at each point of cable laid out from the outdoor to the indoor.

The lightning arrester builds in the circuit to remove the surge voltage to be the source for the damage of field apparatus.

## ③ Power cable

Following is available to reduce the influence of electromagnetic induction noise and electrostatic induction noise from power cable.

### <Isolation from power cable>

Isolate the signal cable from the power cable and avoid to install these cable in parallel.

When cross these cables, cross them vertically.

### <Installation of electrostatic shield>

Shielded signal cable shall be used and the shielded wire shall be grounding.

Make electrical isolation such as using steel conduit for power cable, installing isolation plate between power cable and electrostatic shield, and install them into exclusive steel duct.

## (3) Grounding

Lightening (Thunder) and etc make surge noise. To protect an instrument from surge noise, be sure to ground an instrument.

## 2-4 Maintenance space

A certain maintenance space must be secured around the detector, so that the maintenance staff can perform the safe and correct maintenance and control operation of functions and performance. Pay due attention to secure this space during work plan and execution.

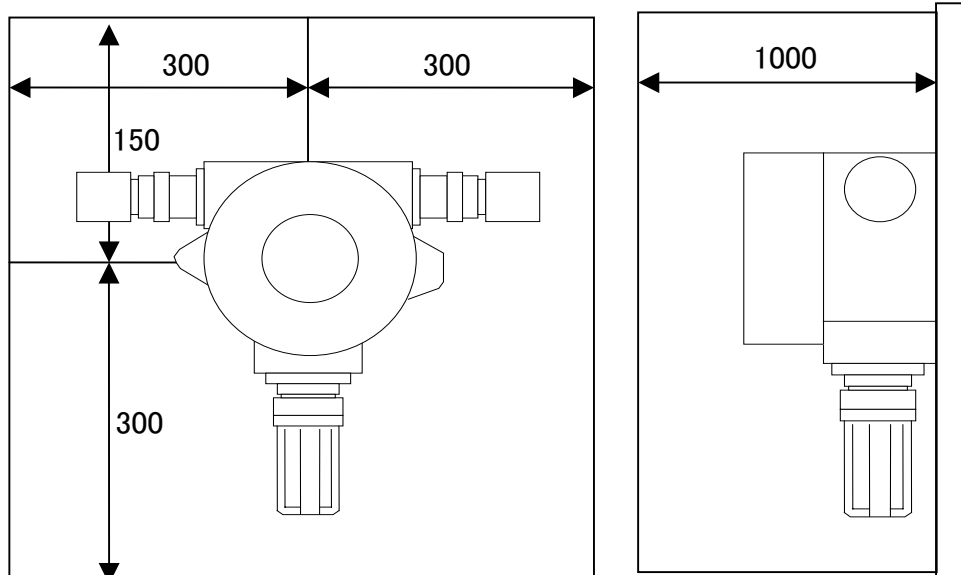

Maintenance space

## 2-5 Installation method

(1) Install the detector housing to a firm surface (wall surface, etc.) with M6 bolts.

### CAUTION

During installation, take care not to drop or throw the detector. Otherwise, the strong impact may cause damage to the equipment.

<Mounting to the wall>

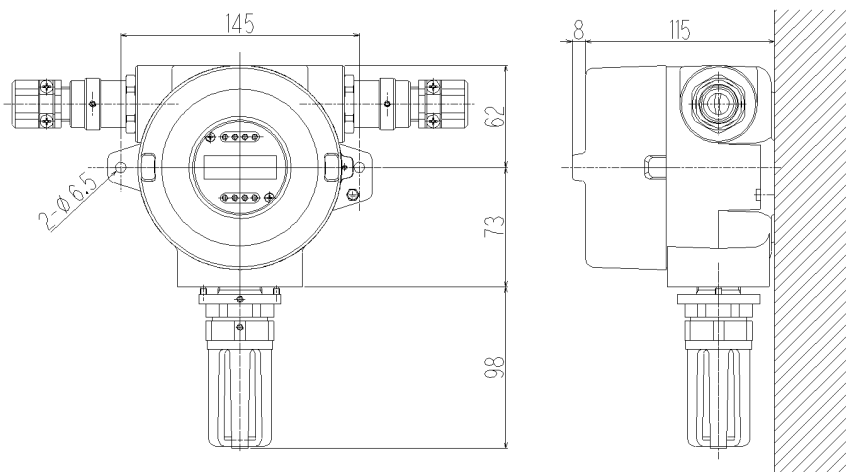

(2) Guide the cable through packing gland A → washer → packing → packing gland B in this order, as shown below figure.

After that, lead the cable into the detector housing and attach crimp ferrules to the end of each conductor.

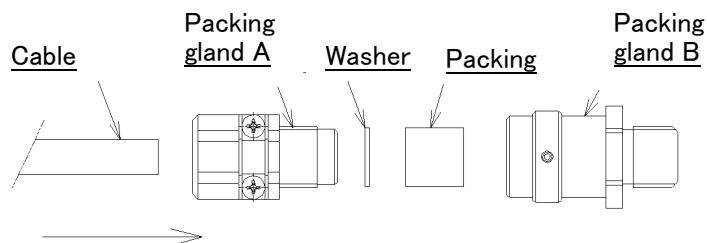

One pair of following packing gland for power/signal cable and alarm relay contact cable is attached to the detector at the time of shipment.

(Specify the size of cable for alarm relay contact)

Purpose	Cable finish O.D.(mm)	Packing I.D.(mm)	Washer I.D.(mm)
For power/signal	$\phi 11 \sim \phi 12$	$\phi 12$	$\phi 13$
For alarm relay contact	$\phi 10 \sim \phi 10.5$	$\phi 11$	$\phi 13$
	$\phi 11 \sim \phi 12$	$\phi 12$	$\phi 13$
	$\phi 13 \sim \phi 13.5$	$\phi 14$	$\phi 14$
	No cable	Plug	

### ⚠ WARNING

- Use the specified packing gland designated by us. If unspecified one is used, explosion proof structure cannot be guaranteed.

### ⚠ CAUTION

- Select the suitable cable and packing gland in reference to the above table.

### ✳ NOTE

- Outer diameter of cable finish is shown as reference. However, it is necessary to confirm the size as it may be different from each cable manufacturer.

Cable core	CVVS 1.25mm <sup>2</sup>	CVVS 2.0mm <sup>2</sup>
2	$\phi 10.0$	$\phi 11.0$
3	$\phi 10.5$	$\phi 11.5$
4	$\phi 11.0$	$\phi 12.0$
5	$\phi 12.0$	$\phi 13.0$
6	$\phi 13.0$	$\phi 14.0$

## 2-6 Wiring method

 **WARNING**

- The supply voltage to this detector is 24VDC  $\pm$ 10%. Operation of this detector with the voltage other than specified voltage may cause failure, damage to the equipment or malfunction.
- Confirm that there is no inflammable/explosive gas around this detector.
- No power switch is provided in this detector. Put off the power source at supply side before wiring construction.

 **CAUTION**

During wiring construction, take care not to damage the internal electronic circuit.

(1) Perform wiring construction with following procedures.

- ① Loosen the lid looseness prevention screw(hexagonal socket headed bolts M3X8).
- ② Rotate the lid counter-clockwise and remove it from housing.  
If it is hard to rotate, use the exclusive jig. to rotate.
- ③ Loosen 2 screws marked \* and draw out both LCD board ass'y and main PCB ass'y.  
But, do not disconnect the cable connected with main PCB and terminal strip.

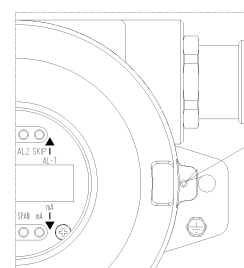

Looseness prevention screw

- ④ Connect lead wires to terminal strip as shown below.  
Be sure to connect wires referring to above steps ②~⑥.

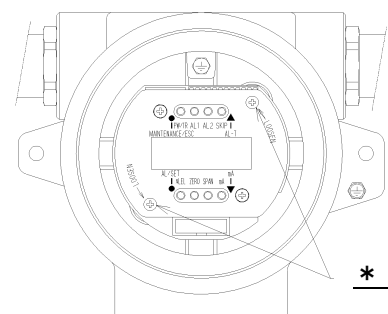

\*

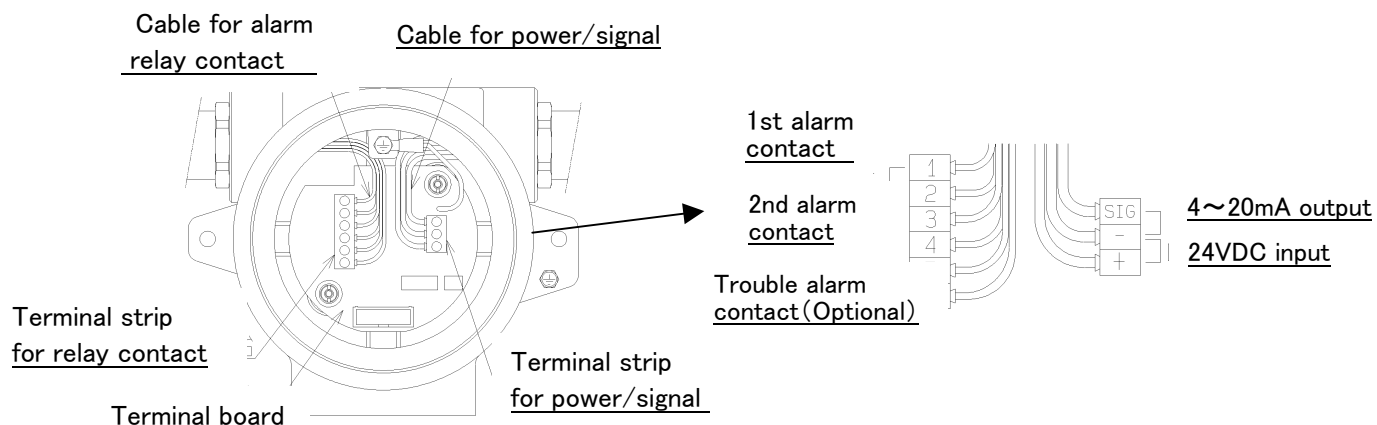

- ⑤ After connecting wires, set holes of main PCB onto pillars and let pillars through into holes of main PCB. Then, tighten it with two screws which are loosened in step③.

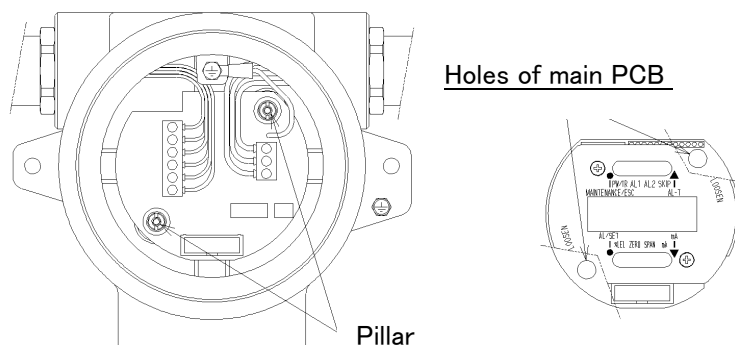

- ⑥ Put the lid onto the housing and rotate it clockwise. If it is hard to rotate, use the exclusive jig.

**! WARNING**

To maintain the explosion proof performance, secure the lid to the housing without gap.

- ⑦ Fasten the lid looseness prevention screw.

- (2) Confirm that terminal strips for power source and relay contacts are mounted. There are power source terminal strip(3p) and relay contact terminal strip(6p) on the terminal board. There are “SIG”, “-“ and “+” marks on the power source terminal strip(3p). “-“ terminal is a common for 24VDC input(+) and SIG output(4~20mA DC) as shown below.

SIG	4~20mA output
-	
+	24VDC input

Grounding terminal strip(6p) is arranged as for the 1<sup>st</sup> alarm contact(2p), 2<sup>nd</sup> alarm contact(2p) and trouble alarm contact(2p) [[option]] .

AL1	Relay contact for 1st alarm
AL2	Relay contact for 2nd alarm
TRB	Relay contact for trouble alarm [[option]]

(3) Connections to the terminal strip shall be done as following manner.

- Make the cable end naked.
- Insert the cable into plug of terminal ① and tighten it by flat-blade screwdriver ②.

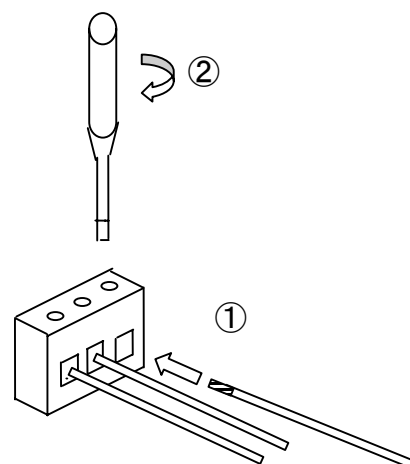

<For connection to the terminal strip>

▪In case of direct connection

Peel length of cable end : 6.0mm

\* Do not make preliminary solder.

▪In case of using the crimp contact

Ferrules : Model A1 5-7 or A2 5-7 (Maker : Phoenix Contact)

Crimping pliers : Model CRIMPFOX UD6 (Maker : Phoenix Contact)

<Torque for terminal strip>

Torque : 0.5~0.8 N·m

Applicable driver : Flat-blade screwdriver (Width 2.5~3mm)



### CAUTION

Be sure to use the specified ferrules. When used with other make ferrules than above, the function of this detector can not be warranted.

<Cables>

Power / Signal cable : CVVS 1.25~2.0mm<sup>2</sup> or equivalent

Alarm relay contact cable : CVVS 1.25mm<sup>2</sup> or equivalent



### CAUTION

Select the suitable cable and cable gland by considering its thickness and diameter.

(4) Carry out connection between equipment as follows.

<Connection of the SD-805RI to the indicator/alarm unit (RI-583 etc.)>

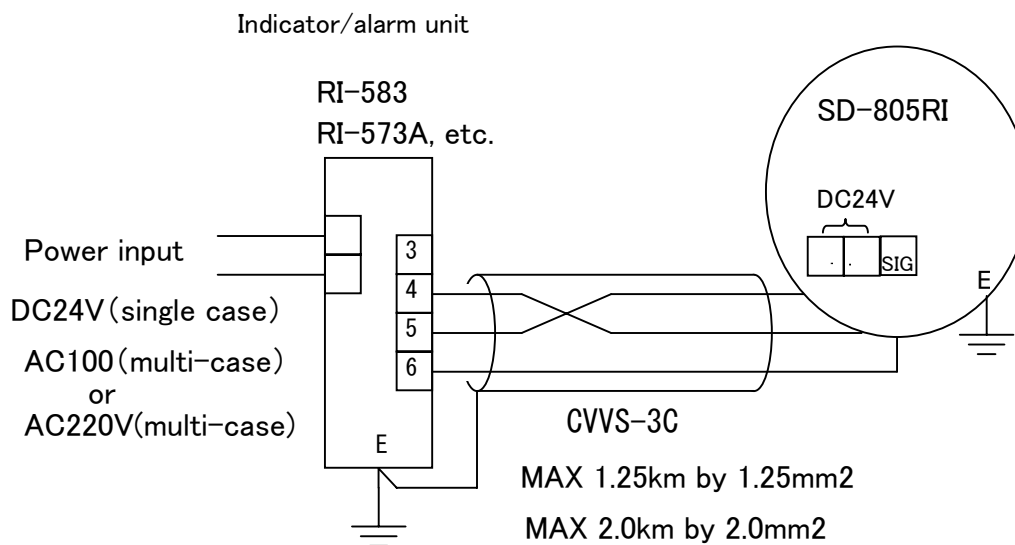

<Connection of 4~20mA output to the DCS, etc.>

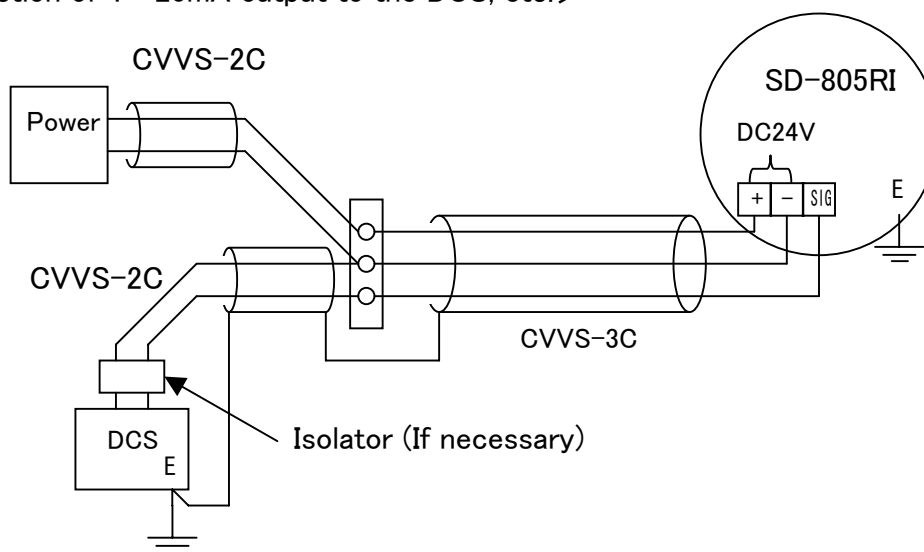

- ( 5 ) For the safety and to protect an instrument from external noise, be sure to make protective grounding before power on.

 **WARNING**

- Be sure to make protective grounding before power on. Use earth cable as thick and short as possible in order to suppress resistance. Use earth(“E”) bolt to fix the earth cable.
- Be sure to make grounding as this detector is explosion(flame) proof design.
- Make grounding corresponding to D-class grounding (Grounding resistance is below  $100\ \Omega$ ).
- Be sure not to close the earth cable to gas pipes.

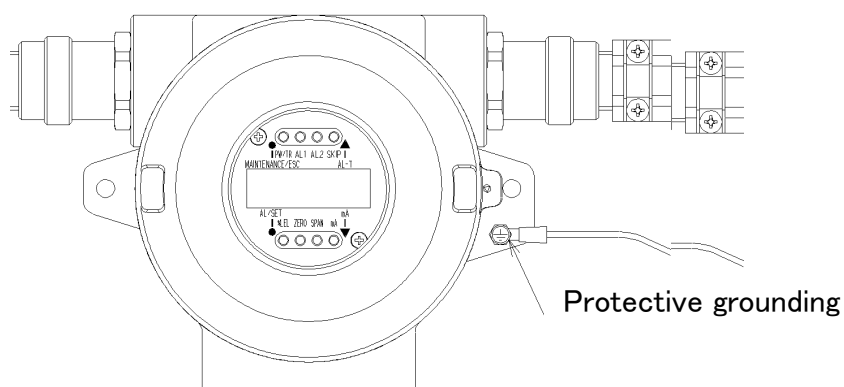



( 6 ) Connect alarm relay contact as following

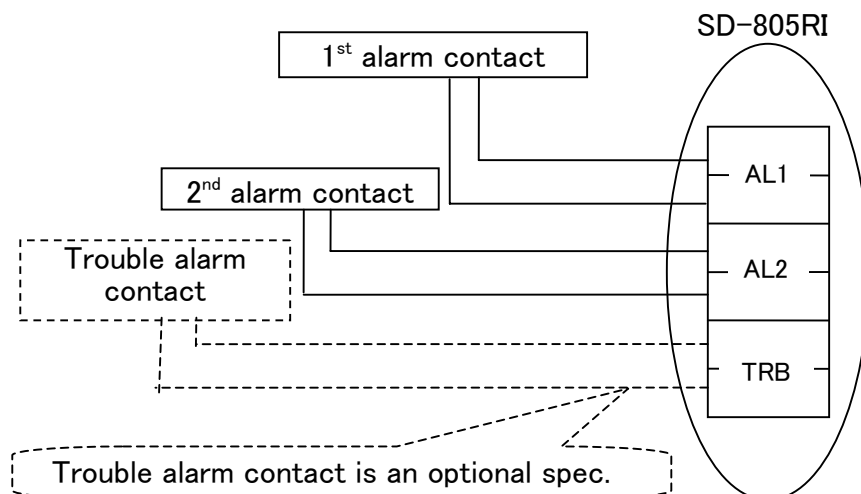

Alarm contacts of this detector is to operate external buzzer or alarm light. Do not use it for the controlling use (such as solenoid valve control etc.) When control the external load, the bad influence may be given to this detector. In such case, the following countermeasures shall be taken to stabilize the action and protect the contact.

- Make relay (contact amplification) with the low voltage relay and connect the surge absorbing parts (Spark killer, diode, etc.) suited for relay coil directly to relay.
- Connect the surge absorbing parts to the load side of relayed relay as occasion demands.

The rating of alarm contact is described based on the resistive load. When use the inductive load for alarm contacts, the very high reverse electromotive voltage may be generated and troubles such as melting of relay contact and reckless drive of CPU tend to be produced.

### ⚠ CAUTION

- The inductive load shall not be used in principle.
- When use the inductive load, make the contact amplification outside, but the outside relay coil belongs to inductive load, use the relay driven by the low voltage and it is protected by an appropriate surge killer.
- As the inductive load, there are following samples.
  - \*Patlight \*External relay \*Buzzer \*Siren \*Fan \*Fluorescent lamp \*Motor etc.
- Normally-closed contact (Break contact) at de-energized condition may change to open contact in a moment due to physical shock.
 

Whenever alarm signals from gas detectors are used with normally-closed contact, please put delayed-circuit(for about one second) to receiver side of normally-closed contact to avoid such phenomenon.
- The trouble contact is an optional function. If it is used, consult with our nearest agent or RIKEN KEIKI.

## 3. OPERATION

### 3-1 Start up method

- (1) With power ON to the unit, the “PW/TR” LED light goes ON and the LCD in the display window shows “----” for warming-up (about 60 seconds) and self-diagnosis. (during this period, the 4-20mA output provides output of 2.5mA)
- (2) In about 60 seconds, the LCD shows the gas concentration value and starts gas detection. When any abnormality is detected in the course of self-diagnosis, PW/TR light is flickering and error message is indicated instead of the gas concentration value.

With this indication error message, refer to 「5-1, Trouble indication and countermeasure」

- (3) When the gas concentration value is indicated, carry out zero and span adjustment according to 「4-4, Gas sensitivity calibration」.

### 3-2 Gas alarm function

When gas concentration exceeds preset alarm level (alarm point), alarm relay contact and alarm light activates. Gas alarm has 1st alarm and 2nd alarm. And each alarm performs individually. When gas concentration exceeds 1st alarm point, 1st alarm relay contact activates and AL1 is lighting. When gas concentration decrease below 1<sup>st</sup> alarm point, 1<sup>st</sup> alarm relay contact is reset, and AL1 light is off (Self reset).

Performance of 2nd alarm is same as 1st alarm.

The action at gas alarm shall follow to the client rule and immediate refuge shall be required. Generally, the following action is taken.

- ① Confirmation of reading at this detector.
- ② Based on gas alarm control concentration, it keeps the safety by keeping away people from the monitoring area.
- ③ When gas concentration display is shown continuously, close the gas valve and confirm that gas concentration gets lower enough.
- ④ Suppose that the leak gas is to remain and provide yourself with protection attire from danger, go to the leak site and check the gas residual condition by portable leak detector.
- ⑤ After checking that there is no danger, the treatment for gas leak shall be taken.

#### \* REMARK

- Instantaneous gas leak may get lower at confirmation time.
- Except gas alarm, it gets alarm condition temporarily by noise or any other accidental conditions.

### 3-3 Trouble alarm function

When the abnormality is issued in the detector, PW/TR light is flickering and error message is displayed. All except for memory trouble (E-00) is self-reset mode. When recovered from trouble condition into normal condition, restart from the action (initial clear) of power on.

For each trouble alarm, refer to「 5-1. Trouble indication and countermeasure」.

### 3-4 Confirmation of preset alarm point

- (1) Touch●mark on AL/SET switch with control key. When the switch is being pressed, 1<sup>st</sup> alarm point and 2<sup>nd</sup> alarm point are indicated by turns in every 1 second on LCD. When 1<sup>st</sup> alarm is indicated, AL1 light is on. And 2<sup>nd</sup> alarm as well.
- (2) When release the control key, indication goes back to gas concentration.

## 4. MAINTENANCE AND INSPECTION

The gas detector alarm is kept in continuous operation over a long period of time and must perform a vital role as a safety device. For this purpose, periodical inspection must be made. The High-pressure Gas Safety Act in Japan sets forth the obligation of periodical inspection of the gas detection instruments.

This is a safety instrument. Be sure to perform periodical inspection. If any abnormality is found, please contact our nearest agent or RIKEN KEIKI at your earliest.

### 4-1 Inspection frequency and items

The inspection includes a daily inspection which a person in charge of control and operation of the gas detection instrument performs inspection before work once a day, and periodical inspections conducted by the service personnel designated by manufacturer. The inspection items are confirmation of the concentration indication on the detector side and confirmation of lights, concentration indication and alarm function on the indicator alarm unit side. It is also necessary to carry out gas calibration at least every 6 months. The law in Japan sets forth that the unit must issue the alarm during the circuit inspection related to alarm while providing normal operation, at least, once a month.

#### •Daily check by user

Inspection point/item	Description	Judgment
Checking of light	Check if the "PW/TR" LED light (power light) is ON.	The "PW/TR" LED light must be ON. If flickering, take an appropriate measure according to 「5-2. Troubleshooting」.
Gas concent. indication check	Check if the gas concentration reading in display part is zero.	The gas concentration indication must be zero in the clean atmosphere. If not, carry out zero adjustment according to the zero adjustment method.
Equipment installation state check	Check if there is any obstruction for detection of the gas concerned.	No obstruction for gas detection. If any, remove such obstruction or move the unit to another place.
Sensor check	Check if the gas inlet is covered with dust or water or if it is discolored.	No abnormality in gas inlet. If it is covered with dust or water, remove and carry out zero and span adjustments according to 「4-4 Gas sensitivity calibration」.
Alarm test	Check if alarm light is activated by switch.	Alarm light is activated normally. If not, contact our nearest agent or RIKEN KEIKI.

#### •Periodical inspection

Following items are performed in periodical inspection.

- ①Daily check    ②Cleaning of detector    ③Calibration  
④Function check    ⑤Parts replacement    ⑥etc.

◎To maintain the safety operation of detector, it is recommended to keep the maintenance contract with our service agent for regular maintenance, adjustment and overhaul etc including the gas sensitivity adjustment(Calibration).

For the detail of maintenance contract, contact our nearest agent.



## WARNING

- This is a safety instrument and the inspection every 6 months or more is mandatory to ensure the safety. If the unit is used by continuously without inspection, the sensor sensitivity may change, resulting in failure of correct detection.
- Before zero adjustment, confirm with a portable gas detector that there is no gas in the neighborhood. If zero adjustment is made in an atmosphere containing gas, no correct calibration is expected. If gas leakage actually occurs, the unit shows the low concentration value, possibly leading to a hazardous state.

## \* Remarks

Be sure to inform sections concerned beforehand when performing adjustment of the gas sensitivity.

### 4-2 Replacement for parts

Following parts are required to be replaced periodically. For replacement, consult with our nearest agent.

	Name of parts	Inspection interval	Replacement interval(year)	Q' ty/unit
1	Main PCB	---	7 ~ 8	1 set
2	Terminal board	---	7 ~ 8	1 set
3	LCD board	---	5 ~ 6	1 set
4	O-ring (for housing)	---	3 ~ 6	1
5	O-ring (for display window)	---	3 ~ 6	1
6	O-ring (for sensor)	---	3 ~ 6	1
7	O-ring (for cable gland of power/signal)	---	3 ~ 6	1
8	O-ring (for cable gland of alarm contact)	---	3 ~ 6	1

- \*1. The above replacement interval is just a standard, and it depends on operating conditions. Also, this does not show a guarantee period.  
Replacement interval changes to the result of regular maintenance check.
- \*2. Replacement of PCB is caused by deterioration of capacitors, etc.
- \*3. The size of O-ring for cable gland of alarm contact depends on the size of cable gland mounted with detector.

#### 4-3 Maintenance mode

Adjustment is performed by control key in maintenance mode without opening the lid.

In maintenance mode, 4-20mA output becomes 2.5mA and SKIP light is flickering.

Following is a menu of maintenance mode and common operation method.

All switch operations are performed by control key.

LCD indication	Menu
	Zero adjustment mode (1.ZERO)
	Span adjustment mode (2.SPAN)
	4mA adjustment mode (3.OUTPUT)
	Alarm point set mode (4.ALARM)
	Alarm test mode (5.TEST)
	Point skip set mode (6.POINT SKIP)
	Factory set mode (7.FACTORY-1)
	Factory set mode (8.FACTORY-2)

#### <To enter into maintenance mode>

- ① To enter into maintenance mode, press ●mark on MAINTENANCE switch with control key for 3 seconds in normal measuring mode.
- ② When entered maintenance mode after 3 seconds, 4-20mA output becomes 2.5mA and skip light is flickering. Release control key after entered.

#### <To enter into each mode>

- ① Change indication number with pressing UP▲ or DOWN▼ switch in MENU condition. Press ●mark on SET switch when the mode you want to enter is indicated.
- ② Display goes to MENU when press ●mark on MAINTENANCE switch during each mode.

#### <To cancel maintenance mode>

- ① Press ●mark on MAINTENANCE switch for about 3 seconds to return detection mode from MENU condition.
- ② When entered detection mode, SKIP light goes off and indicating as it is detection mode.

## 4-4 Gas sensitivity calibration

The following tools and jigs are necessary for zero and span adjustments.

Zero adjustment	Span adjustment
Control key	Control key
/	Calibration adaptor
	Gas sampling bag
	Hexagonal wrench (for M6)
	Flow meter with flow regulator (for 0-3L/min range)
	Suction pump(Above 2 L/min)
	Calibration gas
	Sampling bag for exhaust gas

## (1) Zero adjustment method

In case that the SD-805RI is in operation, zero adjustment can be done immediately. But if it is off, perform zero adjustment after warming up for 30 minutes or more.

Confirm with a portable gas detector that the atmosphere around the detector is clean and does not contain any combustible gas.

If any combustible gas exists around the detector, fill the gas sampling bag (separately available) with high-purity air or fresh air.

Connect the sampling bag filled with high-purity air or fresh air with calibration adaptor and attach it with sensor assembly. Allow the air with pump to flow 2L/min for about 2 minutes. Then, proceed to zero adjustment.

- ① Press ● mark on MAINTENANCE switch with control key for 3 seconds to enter into maintenance mode.
- ② Press ● mark on SET switch in menu display i.L E t.

Zero adjustment mode enters and ZERO light and indication value are flickering.

In this time, there is a case that the indication value is alternated. This is caused by that the actual value is indicated with cancellation of zero suppression which is worked in normal measuring mode.

- ③ After fresh air is introduced and the reading gets stable, press ● mark on SET switch. ZERO light is changed from flickering to steady lighting, and indication value on LCD goes to zero (from flickering to steady lighting). This shows that zero point is adjusted. (ZERO adjustment is completed.)

**【Example】**

<Normal condition>



<In case that zero cannot be adjusted

- ① When the zero point is left from zero excessively, indication is not "0.0."  
In this case, 4-digit number is displayed on LCD. ZERO light is still flickering.
- ② Check that the fresh air is supplied and there is no leakage from calibration kit/jig.  
If there is some error, make zero adjustment again by pressing ● mark on ESC switch.
- ③ In case that there is no error for adjustment procedures, press UP switch ▲ or DOWN switch ▼ to adjust the value within 2950~3050 and press ● mark on SET switch. ZERO light is changed from flickering to steady lighting, and indication value on LCD goes to zero.  
This shows that zero point is adjusted (ZERO adjustment is completed).

<In case that zero cannot be adjusted>

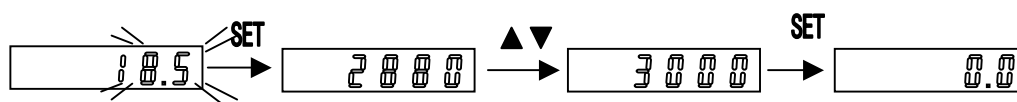

**! CAUTION**

If indication value does not become zero after zero adjustment, check the instrument and piping, and make zero adjustment again. But it cannot be still adjusted zero, gas sensor has trouble. Put the power off. And consult with nearest agent.



## (2) Span adjustment

Be sure to adjust span after completion of zero adjustment.

Prepare about 5L of calibration gas whose concentration has been confirmed beforehand (the appropriate concentration is around 1/2 of the LEL, that is 50%LEL) in a gas sampling bag for each unit.

Connect gas sampling bag with calibration adaptor, pump and flowmeter (with regulator) and then, adjust flow rate at 2L/min.

- ① Press ●mark on MAINTENANCE switch for 3 seconds to enter into maintenance mode.
- ② Press ●mark on SET switch in MENU display 2.5 P n. When span adjustment mode is entered, SPAN light and indication value on LCD are flickering.
- ③ Connect an exhaust bag to outlet of calibration adaptor.
- ④ Connect the sampling bag for calibration gas as prepared above to the air/gas inlet of the pump.

## &lt;Connection diagram&gt;

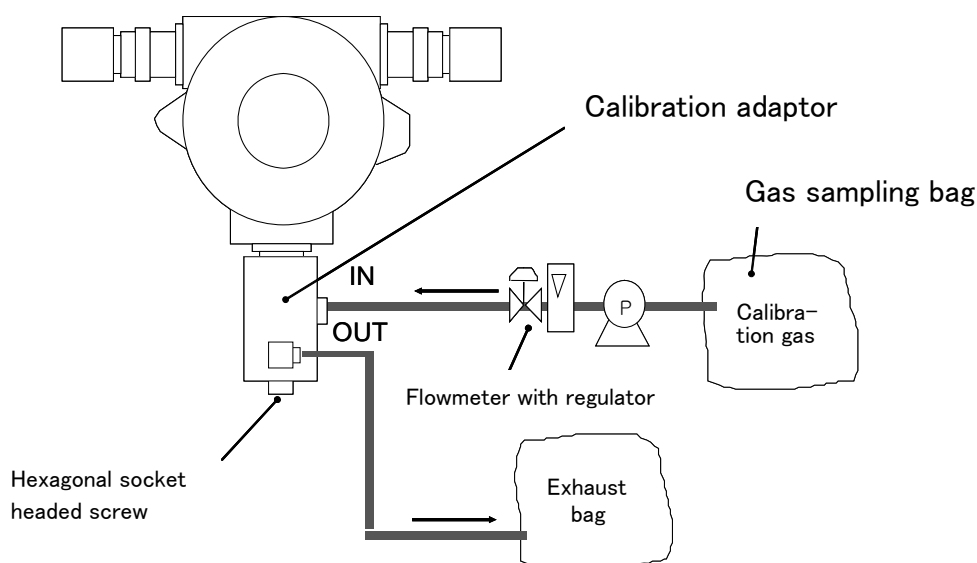

- ⑤ When the calibration gas is introduced into the sensor, the indication of the indicator rises. If the indication is not equal to the concentration value of calibration gas in 2 minutes after start of introduction, press the control key to the UP switch▲ or DOWN switch▼ to allow the indication to match to the calibration gas concentration.
- ⑥ After adjustment, press ●mark on SET switch to decide. SPAN light is changed from flickering to steady lighting which shows that SPAN adjustment is completed.

- ⑦ Upon completion of the span adjustment, remove the sampling bag from the inlet of the calibration adaptor and proceed zero adjustment again.

**\* REMARKS**

A dedicated tool is necessary for the span adjustment. It is recommended to request this adjustment to our nearest agent.

(3) Span adjustment method by substitute gas

Fundamentally, span adjustment shall be done by actual gas (objective gas). When it is difficult to prepare the actual gas (objective gas), make span adjustment by substitute gas. Following is the difference point between span adjustment by actual gas and by substitute gas.

「Calibration gas」

Prepare substitute gas described in the label (name of gas and its concentration) for conversion factor instead of actual gas. The label for conversion factor is adhered in front of detector housing.

Calibration procedures are the same as above step “(2) Span adjustment.”

「Conversion factor」

Calculate the adjusting value by multiplying the conversion factor with calibration gas concentration.

「Example」

In case that the label is described as;

Substitute gas	:	CH4 50±5%LEL
Conversion factor	:	1.200

When the substitute gas for calibration is 52.5% LEL CH4, adjust the reading at 63.0% LEL (Substitute gas [52.5] x conversion factor [1.200] )

## 4-5 Adjustment of 4mA output

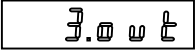
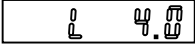
- ① Press ●mark on SET switch in MENU display  .
- ② When signal output adjustment mode is entered,  is displayed on LCD and zero signal value (4mA ) is output.
- ③ Adjust indication value to zero(4mA) on indication part of DCS and etc which is connected separately by pressing UP switch▲ and DOWN switch▼.
- ④ After adjustment, press ●mark on SET switch to decide. When it is decided, SPAN light turns on.

 **CAUTION**

4mA output has been adjusted at the factory before shipment. If the zero point on indicator side connected with this detector is so much deviated, check the setting at indicator side connected with this detector.

## 4-6 Change of alarm point

1<sup>st</sup> alarm and 2<sup>nd</sup> alarm can be alternated individually.

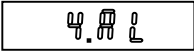
- ① Press ●mark on SET switch in menu display  .
- ② When alarm set mode is entered, AL light is on and current 1<sup>st</sup> alarm point is displayed on LCD.
- ③ When changing alarm point, press ●mark on SET switch.
- ④ Then, AL1 light is changed from steady lighting into flickering. Press UP switch▲ or DOWN switch▼ to adjust.
- ⑤ After adjustment, press ●mark on SET switch to decide. After decision, AL1 light turns on. When cancel the adjusted value, press ●mark on ESC switch, and it returns to step ①.
- ⑥ Then, press UP switch▲.
- ⑦ Current 2<sup>nd</sup> alarm point is displayed on LCD. And AL2 light is turned on.
- ⑧ 2<sup>nd</sup> alarm point can be changed as same as 1<sup>st</sup> alarm point.

## 4-7 Alarm (Transmission) test

Alarm functions can be confirmed.

**CAUTION**

When make alarm (transmission) test, announce it to respective department beforehand as this detector provides an alarm contact.

Carry it out after making proper treatment not to give an influence to others.

- ① Press ●mark on SET switch in menu display .
- ② Press UP switch ▲ or DOWN switch ▼ to select whether alarm contact is activated or not.  
 (No operation) ↔ (Operation)
- ③ Press ●mark on SET switch to decide.
- ④ When alarm test mode is entered, test level (zero value) is displayed on LCD display.  
When alarm contact is set to “ON” at this time, ZERO and SPAN lights are flickering simultaneously.
- ⑤ To press UP switch▲ or DOWN switch▼, test level can be changed between 0 to full scale and over scale (4-20mA output is also changed according to indication).
- ⑥ When test level exceeds 1<sup>st</sup> alarm point, 1<sup>st</sup> alarm is activated.  
(After alarm delay time passed, AL1 light is on, and 1<sup>st</sup> alarm contact is activated if “ON” is chosen.)
- ⑦ When test level exceeds 2<sup>nd</sup> alarm point, 2<sup>nd</sup> alarm is activated.  
(After alarm delay time passed, AL2 light is on, and 2<sup>nd</sup> alarm contact is activated if “ON” is chosen.)

## 4-8 Setting of point skip

Maintenance condition can be set compulsorily.

4-20mA : 2.5mA (Fix)

Alarm contact : OFF

Alarm light : OFF

- ① Press ● mark on SET switch in menu display 6.P5.
- ② When point skip set mode is entered, current set condition is displayed on LCD.
- ③ To set point skip condition, press UP switch▲ or DOWN switch▼ to change as

0.FF → 0.n.

To return from point skip condition, change as 0.n → 0.FF.

Then, press ● mark on SET switch to decide.

After decision, SPAN light turns on..

## 4-9 Storage or treatment when not in use for a long time

- (1) Store the sensor as attached to the detector in a place not exposed to dust and water splash.
- (2) Storage conditions
  - Temperature : 0~+30°C
  - Humidity : Below 85%RH
  - Environmental conditions: Places without organic solvent and gas generation.

**CAUTION**

When gas detector is used after long storage period, make gas sensitivity calibration again.

## 5. TREATMENT AT AN ABNORMAL CASE

### 5-1 Trouble indication and countermeasure

This section describes a procedure to determine the fault location when any trouble is found as a result of [ 4. Maintenance and inspection].

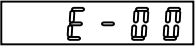
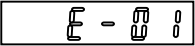
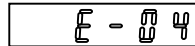
Indication	Content	Counter
	Indicated when any abnormality occurs in the equipment.	Turn on power again. If not restored, consult with our nearest agent.
	Indicated when the sensor is disconnected.	Consult with our nearest agent. Check the connector cable and repair the default point.
	Indicated when sensor zero point is excessively drifted.	When the trouble cannot be cleared by zero adjustment, consult with our nearest agent.
	Indicated when zero point gets in minus level.	Drastic change of circumstance temperature may cause the fluctuation of sensor zero point. Put protection cover and etc. not to change temperature around detector.

### 5-2 Trouble shooting

#### (1) PW/TR light is not on (Power is not supplied)

Probable causes	Recommended action
Power cable connected correctly?	Connect power cable correctly.
Is power voltage normal?	Supply the rated power voltage.

#### (2) Abnormal performance

Probable causes	Recommended action
Sudden surge noise can be considered.	To recover, turn off and turn on the power again for re-start of operation. When such takes place oftentimes, take an appropriate countermeasure for noise.

## ( 3 ) No zero adjustment available

Probable causes	Recommended action
Fresh air supplied to sensor?	Supply fresh air.
Moisture is condensed to the sensor	Normal measurement is impossible when condensing.
Sensor sensitivity is reduced	When the sensor is covered with water splash, dust and etc., the adjustment is difficult to perform. In such case, consult with our nearest agent.

## (4) No span adjustment available

Probable causes	Recommended action
Calibration gas prepared correctly?	Use the correctly prepared gas for re-calibration.
Zero adjustment performed?	Be sure to perform zero adjustment before span adjustment.
Calibration gas supplied correctly to the sensor?	Carry out calibration according to [4-4.Gas sensitivity calibration]

## (5) No control available with control key

Probable causes	Recommended action
Press control key correctly?	Press control key correctly on the panel.
Control key normal condition?	Function is reduced when it has dirty and damage.
Operation is done correctly?	Latching time of about 3 seconds is required on some operation for prevention of error performance.

## (6) Indication rises without gas

Probable causes	Recommended action
Temperature changed drastically?	Direct sunshine, drastic temperature change and etc. may cause the indication rising. Change of installation point and putting the weather proof cover (option) are effective for them.
Humidity changed drastically?	Drastic humidity change may cause the indication rising as same as temperature. Keeping appropriate distance between detector and the ground is effective.
Influenced from external noise?	Reduce influence from noise referring to [2-2.Cautions for installation and handling], and [2-3.Cautions in the system engineering.
Atmospheric pressure is fluctuated	IR type detector is influenced with atmospheric pressure and changes in proportional to atmospheric pressure.

(7) Indication is full scale overed.

Probable causes	Recommended action
Sensor cable is damaged.	There is a case that trouble indication 「E-01」 does not displayed but the reading is full scale overed which is depending on the position of damage sensor cable. Consult with our nearest agent.
Contact failure of sensor connector	There is a case that trouble indication 「E-01」 does not displayed but the reading is full scale overed due to it. Check the sensor connector and consult with our nearest agent.
Dirtiness of sensor.	The indication is influenced when inside of the sensor has dirty and water splashed. Do not make detector dirty. Change of installation point and drip proof cover (option) are effective.
Influence from external noise.	Reduce influence from noise referring to [2-2.Cautions for installation and handling], and [2-3.Cautions in the system engineering.



### CAUTION

Check the existence of gas leakage first if the reading is increased or over-scaled.



## 6. DEFINITION OF TERMS

Non-dispersed infrared ray type

This is a principle for the sensor integrated into this detector.  
For the details, refer to [8. Detection principle].

Initial clear

The output from the detector fluctuates for a while after power application.  
This function is to suppress alarm during this period.

Full scale

The maximum value of the detection range.

%LEL

The unit with the lower explosive limit of the flammable gas to be detected being 100%.

Calibration

Matching the equipment indication to the calibration gas concentration value by using the calibration gas.

Zero suppression

Function to make sensor drift not to be noticeable.

Alarm delay time

Function to hold operation temporarily in order to prevent error alarm by external noise.

Point skip

Function to stop gas detection temporarily during the maintenance and etc.

## 7. PRODUCT SPECIFICATIONS

### 7-1 Standard specifications

Model	SD-805RI
Detection principle	Non-dispersed infrared ray type
Gas to be detected	Combustible gas such as methane or hydrocarbon (HC), etc.
Sampling method	Diffusion
Detection range	0-100%LEL
Response time	Within 30 sec. to 60% of concentration (at the same condition) Response time varies depending on the kind of gas.
Transmission method	3-wire type analog transmission (power, signal, common)
Transmission distance	1.25 km or less with CVVS (1.25 mm <sup>2</sup> ) cable 2 km or less with CVVS (2.0 mm <sup>2</sup> .) cable
Alarm output	2 alarm levels. • Normally-open or normally-close contact (Specify either one). • Rated 1A at 30VDC (Resistive load).
Preset alarm point	1 <sup>st</sup> : 25%LEL 2 <sup>nd</sup> : 50%LEL (Adjustable at any level between 10-100%LEL)
Alarm delay time	About 2 seconds
Output signal	4-20mA (current source type) Maximum load : 300 Ω 0.5mA ... at malfunction 2.5mA ... in the maintenance mode and during initial operation Note : Linear up to 22mA.
Indication function	Concentration indication : 5-digit LCD, 7-segment, 4-20mA indication PW/TR...Power/Trouble indication (Green/flickering or steady on) AL1 ... 1 <sup>st</sup> alarm indication (Yellow/flickering or steady on) AL2 ... 2 <sup>nd</sup> alarm indication (Red/flickering or steady on) SKIP ... Maintenance mode indication (Green/flickering or steady on) %LEL ... %LEL range (Green/steady on) ZERO ... Zero adjust. mode (Red/flickering or steady on), others. (off) SPAN ... Span adjust. mode (Red/flickering or steady on), others. (off) mA ... mA indication (Green/steady on), others. (off)
Self-diagnosis function	Gas sensor wire breakage, zero abnormality, system trouble Indication : PW/TR (Green/flickering), LCD message. Output signal : 0.5mA (fix)
Initial clear	Approx 60 seconds after power ON (LCD indication "----")
Zero suppression	6% of F.S. (standard)
Power requirement	Voltage : DC24V ± 10% Consumption : Max.4W
Operating temperature/humidity	-10~+40°C, 95%RH or less (Non-condensing)
Setting & adjustments	ZERO/SPAN adjustment, etc. (non-contact) with the control key
Overall dimensions	Approx.127(W) x 233(H) x 115(D)mm
Weight	Approx.3.5kg
Structure	Flame proof construction EXd II BT4X, Approval No.TC17324

- 7-2 Standard accessories
- Control key
  - Operating instruction manual

## 8. DETECTION PRINCIPLE

Model SD-805RI applies Non-Dispersive Infrared Ray Absorption(NDIR) technique to detect objective gas.

The infrared beam emitted from the light source passes through the measuring cell and reaches to IR sensor. The objective gas enters into measuring cell through flame arrestor (sintered metal) since the measuring cell has a permeable hole.

When objective gas is entered into measuring cell, the amount of infrared ray to be received by IR sensor decreases since the infrared ray emitted from IR source is absorbed by the objective gas.

This decreased amount is detected by IR sensor and output as gas concentration. There is an optical band pass filter in front of IR sensor which can pass the absorption wave of objective gas. Then, there is no sensitivity against CO<sub>2</sub> and CO etc. which have the different absorption wave from the objective gas. Furthermore, there is no sensitivity against N<sub>2</sub> and H<sub>2</sub> etc. which cannot absorb infrared ray.

The light source, measuring cell and IR sensor, etc are housed in a flame arrestor and designed as explosion proof (Flame proof)

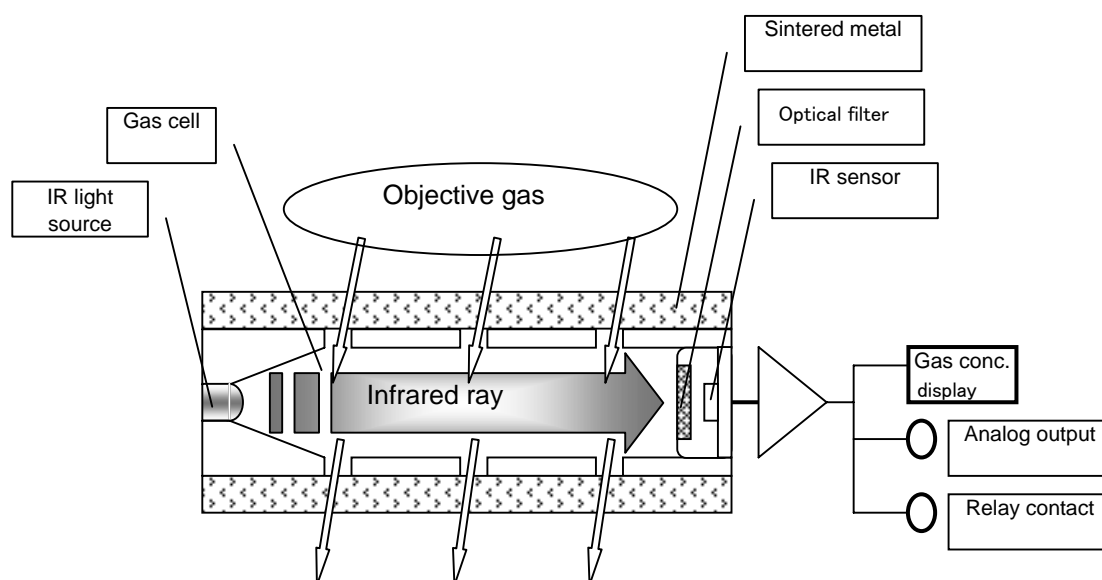

## 9. WARRANTY

RIKEN KEIKI CO., LTD. warrants gas alarm equipment manufactured and sold by us to be free from defects in materials and workmanship for a period of one year from date of shipment from RIKEN KEIKI CO., LTD. Any parts found defective within that period will be repaired or replaced, at our option, free of charge, F.O.B. Factory. This warranty does not apply to those items which by their nature are subject to deterioration or consumption in normal service, and which must be cleaned, repaired or replaced on a routine basis. Such items may include :

- a) Lamp bulbs and fuses
- b) Pump diaphragms and valves
- c) Absorbent cartridges
- d) Filter elements
- e) Batteries

Warranty is voided by abuse including rough handling, mechanical damage, operation, alteration or repair procedures not in accordance with instruction manual. This warranty indicates the full extent of our liability, and we are not responsible for removal or replacement costs, local repair costs, transportation costs, or contingent expenses incurred without our prior approval.

THIS WARRANTY IS EXPRESSLY IN LIEU OF ANY AND ALL OTHER WARRANTIES AND REPRESENTATIONS, EXPRESSED OR IMPLIED, AND ALL OTHER OBLIGATIONS OR LIABILITIES ON THE PART OF RIKEN KEIKI CO., LTD. INCLUDING BUT NOT LIMITED TO, THE WARRANTY OF MERCHANTABILITY OR FITNESS FOR A PARTICULAR PURPOSE. IN NO EVENT SHALL RIKEN KEIKI CO., LTD. BE LIABLE FOR INDIRECT, INCIDENTAL OR CONSEQUENTIAL LOSS OR DAMAGE OF ANY KIND CONNECTED WITH THE USE OF ITS PRODUCTS OR FAILURE OF ITS PRODUCT TO FUNCTION OR OPERATE PROPERLY.

This warranty covers instruments and parts sold (to users) only by authorized distributors, dealers and representatives as appointed by RIKEN KEIKI CO., LTD.

We do not assume the indemnification for any accident or damage caused by the operation of this gas monitor and our warranty is limited to the replacement of parts or our complete goods.